



# Low pressure indoor copper cylinders

Owner and installer guide

**Rinnai**

---

# Important

---

Cylinders shall be installed in accordance with:

- Manufacturer's installation instructions
- Current AS/NZS 3000, AS/NZS 3500, and G12/AS1

Must be installed, commissioned, serviced, repaired, and removed by authorised personnel.

Not suitable as a spa or swimming pool heater.

- Owner, please retain this guide for future reference
- Installer, please leave this guide with the owner

## **Warning**

Improper installation, adjustment, alteration, service and maintenance can cause property damage, personal injury or loss of life.

This appliance is not to be used by persons (including children) with reduced physical, sensory or mental capabilities, or lack of experience and knowledge, unless they have been given supervision or instruction.

For more information about buying, using, and servicing of Rinnai appliances call: 0800 RINNAI (0800 746 624).

Rinnai New Zealand Limited  
105 Pavilion Drive, Mangere, Auckland  
PO Box 53177, Auckland Airport, Auckland 2150

Phone: (09) 257-3800  
Email: [info@rinnai.co.nz](mailto:info@rinnai.co.nz)  
Web: [rinnai.co.nz](http://rinnai.co.nz)  
[youtube.com/rinnainz](https://www.youtube.com/rinnainz)  
[facebook.com/rinnainz](https://www.facebook.com/rinnainz)

---

# Contents

---

About your cylinder.....	4
Maintenance and servicing.....	4
Troubleshooting.....	6

## Installation

Specification summary.....	8
Dimensions.....	9
Plumbing setup.....	11
Storage and delivery temperatures.....	12
Water quality.....	13
Electrical supply and connections.....	14
Valves and fittings.....	15
Commissioning.....	15
Limited Warranty.....	16
Warranty examples in the real-world.....	18

### **Please note**

Only a licensed tradesperson can install, adjust, maintain, service, and remove this water heater. Any work carried out by a non-licensed tradesperson is illegal and will void any warranty.

# About your cylinder

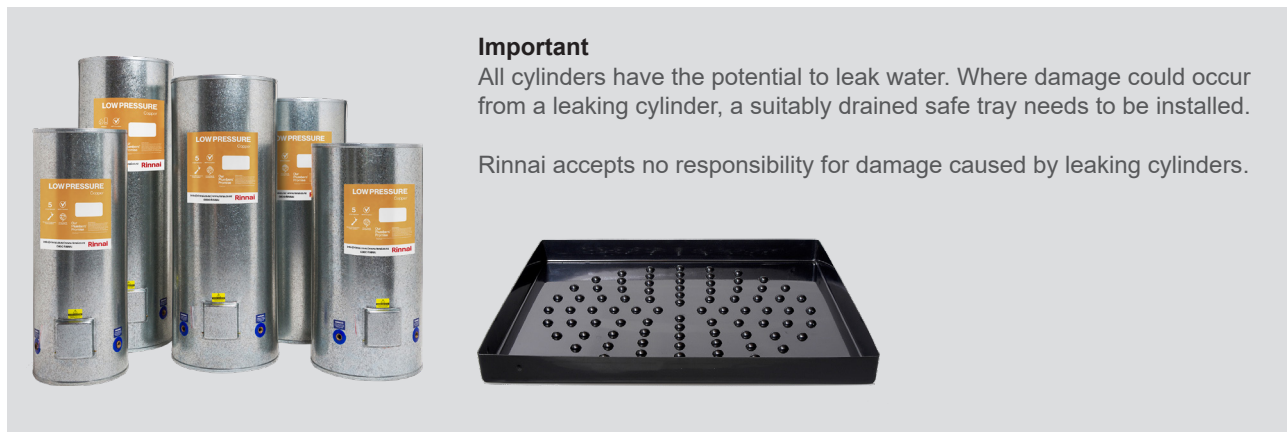

## Important

All cylinders have the potential to leak water. Where damage could occur from a leaking cylinder, a suitably drained safe tray needs to be installed.

Rinnai accepts no responsibility for damage caused by leaking cylinders.

## Safety messages

### Safety devices

Your cylinder should have the following safety devices fitted:

- Valve vented system
  - pressure reducing valve
  - pressure relief valve
  - tempering valve
  - energy cutout thermostat
  - cold water expansion valve
- Open vented systems
  - pressure reducing valve
  - tempering valve
  - energy cutout thermostat
  - vent pipe

### DANGER

The operation of the thermal cutout can indicate a dangerous situation. Do not reset the thermal cutout until the water heater has been serviced by a qualified person.

Do not operate the system unless all the safety devices are fitted and are in working order. It is also important that you do not tamper or remove any of these devices.

### Element cover

Do not remove the element cover as this will expose 230 V wiring and must only be removed by an authorised person.

### Thermostat setting

Must only be adjusted by an electrician or other suitably qualified tradesperson.

### Damaged components

If any component is damaged, it must be replaced by an authorised person using Rinnai replacement parts.

### Child supervision

Children should be supervised to ensure they do not play with any part of the hot water system.

### Hot pipe work

Care should be taken not to touch the pipe work from the cylinder as this could be very hot.

### Cylinder thermostat setting

To meet the New Zealand Building Code requirement<sup>1</sup> to disinfect water for legionella bacteria<sup>2</sup>, the thermostat has been set to 65 °C (for standard cylinders), and approximately 70 °C (for wetback cylinders).

### Turning the cylinder on/off

If you plan to be away for a few nights we suggest you leave the system switched on. If it is necessary to switch it off, when switching back on, remember that the cylinder will take time to heat back up again.

### Draining and filling the cylinder

This normally occurs during installation or servicing and must be carried out by an authorised person.

<sup>1</sup> Clause G12.3.9, Acceptable Solution G12/AS1 6.14.3

<sup>2</sup> Legionella is a bacterium that can cause Legionnaires' disease—a severe form of pneumonia

# Maintenance and servicing



Hot water systems require regular maintenance and servicing. To ensure longevity of your cylinder we recommend the following.

<b>Period</b>	<b>What needs to be done</b>
Year five	Inspection and service of the entire hot water system, including the element*
Every 24 months after year five	Inspection and service of the entire hot water system, including the element*
* In hard water areas the element(s) must be periodically descaled. To do this the cylinder must be drained and the element(s) removed	

Rinnai has a maintenance, service, and spare parts network with personnel who are fully trained and equipped to give the best advice on your Rinnai product. Regular maintenance and servicing is not covered by the Rinnai warranty.

For help locating a service person in your area call 0800 RINNAI (0800 746 624).

# Troubleshooting

Do not attempt to carry out any work other than that mentioned in this troubleshooting section. If you have any other faults or problems, please contact your installer, or contact Rinnai.

<b>Problem</b>	<b>Possible solution</b>
Lack of hot water or no hot water	<p>Is there electricity supply to the cylinder?</p> <p>Check that the isolating switch marked 'hot water' or 'water heater', at the meter box, is switched on. Also check any isolating switches near the water heater are switched on.</p> <p>Check the fuse or circuit breaker marked 'hot water' or 'water heater' at the meter box. Repeated failure of the fuse or tripping of the circuit breaker indicates a fault, which must be investigated by an authorised tradesperson.</p> <p>Most hot water cylinders are controlled at peak times by your electricity supplier via a ripple relay. Contact your electricity supplier to determine if there have been any issues with the power supply.</p>
Lack of hot water or no hot water	<p>Are you using more hot water than you think?</p> <p>Often you don't realise how much water is actually being used. This applies especially when showering. Typical flow rates for showers is approximately 8-10 litres per minute. Conduct a simple experiment by placing a measured bucket under your shower for ten seconds and multiply by six to determine the amount of water produced over a minute. If your result is significantly more than the rates mentioned you may want to consider installing a low flow shower rose—available at all good plumbing stores.</p>
Lack of hot water or no hot water	<p>Cold water relief valve discharging continuously?</p> <p>It is normal for the cold water relief valve to discharge a small quantity of water through the drain line. If water is discharging continuously there may be a fault with one of the valves, contact the installer to discuss.</p>
Water is too hot	<p>If possible check the temperature of the water coming out of a hot water tap with a thermometer. If it is higher than 55 °C then this indicates a problem with your system—contact an electrician for advice.</p>
High electricity bills	<p>If you think your electricity bill is too high, investigate the following:</p> <ul style="list-style-type: none"><li>• Has your electricity tariff changed?</li><li>• Is your cold water relief valve discharging continuously?</li><li>• Are you using more hot water than normal?</li><li>• Has there been any leaking hot water pipes, or taps?</li></ul>

# Installation

Installation, servicing and repair shall be carried out only by authorised personnel.

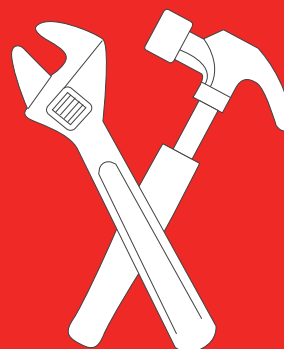

## Model numbers

LOW PRESSURE UNDERSINK	
LCUS00934010	LCUS01143010
LCUS02234010	LCUS04444520
LOW PRESSURE STANDARD	
LC04444520	LC09043020
LC09050020	LC09053020
LC13550020	LC135551020
LC13553020	LC13554020
LC13555020	LC18051020
LC18051030	LC18053020
LC18053030	LC18054020
LC18054030	LC18055020
LC18055030	
LOW PRESSURE WETBACK	
LCW13555020	LCW13551020
LCW13553020	LCW13554020
LCW13555020	LCW18051020
LCW18051030	LCW18053020
LCW18053030	LCW18054020
LCW18054020	LCW18054030
LCW18055020	LCW18055030



# Specification summary



## Suitability

- Low pressure indoor residential and commercial applications
- Left, right, or bottom cold inlet connections

Not suitable as a pool or spa heater.

System should be located and arranged so as to achieve the closest proximity to water draw off points.

Not suitable for water that is hard and/or aggressive, refer water quality parameters on p17.

<b>Construction</b>	Inner cylinder: High grade copper Outer casing: Galvanised steel		
<b>Thermal insulation</b>	CFC-free polyurethane foam, compliant with MEPS standard		
<b>Operating pressures</b>	Maximum inlet pressure - 76 kPa Maximum working pressure - 76 kPa		
<b>Element</b>	Incoloy stainless alloy steel		
<b>Thermostat standard</b>	7 " Cotherm probe 20 A over-temperature thermostat, manually resettable at 85 °C. Factory preset at approx. 65 °C.		
<b>Thermostat wetback</b>	7 " Cotherm probe 20 A (no over- temperature) thermostat. Factory preset at approx. 70 °C.		
<b>IP rating</b>	IPX1		
<b>Compliance</b>	No cylinder wrap required. All Rinnai cylinders meet the NZ Minimum Energy Performance Standard (MEPS).		
<b>Weights - empty / full</b> (* includes 174 / 176 L)	<b>9 L</b>	7 kg	16 kg
	<b>14 L</b>	8 kg	22 kg
	<b>22 L</b>	9 kg	31 kg
	<b>44 L</b>	11 kg	55 kg
	<b>90 L</b>	16 kg	106 kg
	<b>135 L</b>	21 kg	156 kg
	<b>180 L*</b>	26 kg	206 kg

## Cylinder recovery times (theoretical)

Based on a thermostat temperature setting of 60 °C and an incoming water temperature of 15 °C.

- 9 L = 32 mins. (1 kW)
- 14 L = 49 mins. (1 kW)
- 22 L = 1 hr 17 mins. (1 kW)
- 44 L = 1 hr 10 mins. (2 kW)
- 90 L = 2 hrs 38 mins (2 kW)
- 135 L = 3 hrs 56 mins (2 kW)
- 180 L = 5 hrs 15 mins (2 kW)
- 180 L = 3 hrs 30 mins (3 kW)



# Underbench

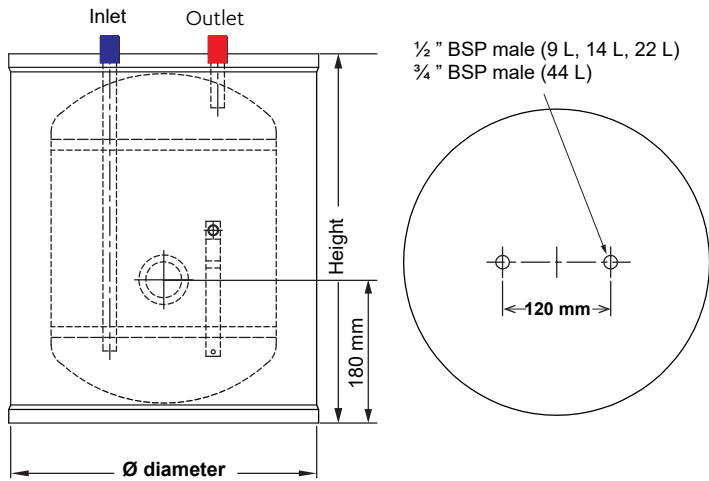

Model	Diam.	Height	Element
9 L	Ø 340 mm	315 mm	1 kW
14 L	Ø 340 mm	420 mm	1 kW
22 L	Ø 340 mm	575 mm	1 kW
44 L	Ø 445 mm	585 mm	2 kW

# Standard / wetback

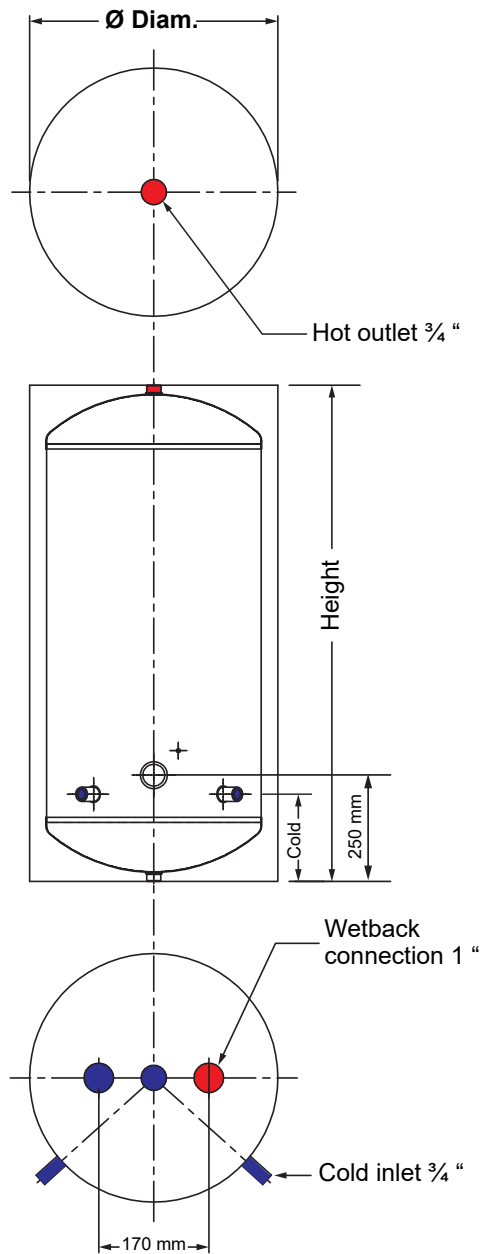

Model	Diam.	Height	Element	Height to cold	Wetback connection
44 L	Ø 445 mm	585 mm	2 kW	120 mm	N/A
90 L	Ø 430 mm	1115 mm	1 kW	150 mm	N/A
90 L	Ø 500 mm	820 mm	2 kW	175 mm	N/A
90 L	Ø 530 mm	745 mm	2 kW	175 mm	N/A
135 L	Ø 500 mm	1165 mm	2 kW	175 mm	1"
135 L	Ø 510 mm	1170 mm	2 kW	175 mm	1"
135 L	Ø 530 mm	1055 mm	2 kW	175 mm	1"
135 L	Ø 540 mm	1035 mm	2 kW	200 mm	1"
135 L	Ø 550 mm	980 mm	2 kW	180 mm	1"
174 L	Ø 510 mm	1495 mm	2 kW	175 mm	1"
174 L	Ø 510 mm	1495 mm	3 kW	175 mm	1"
176 L	Ø 530 mm	1370 mm	2 kW	175 mm	1"
176 L	Ø 530 mm	1370 mm	3 kW	175 mm	1"
180 L	Ø 540 mm	1320 mm	2 kW	200 mm	1"
180 L	Ø 540 mm	1320 mm	3 kW	200 mm	1"
180 L	Ø 550 mm	1295 mm	2 kW	180 mm	1"

# Plumbing setup

The cylinder must be installed in accordance with G12/AS1, and AS/NZS 3500.4. For service and maintenance, please allow sufficient room for access to covers and valves. All hot water pipe work should be insulated with polythene foam or equivalent insulation to optimise performance and energy efficiency. This includes all water fittings.

All hot water supply parts must comply with AS/NZS 3500.4 and G12/AS1.

For an appliance intended to be permanently connected to the water mains and not connected by a hose set.

## Plumbing setup for a low pressure cylinder - valve vented

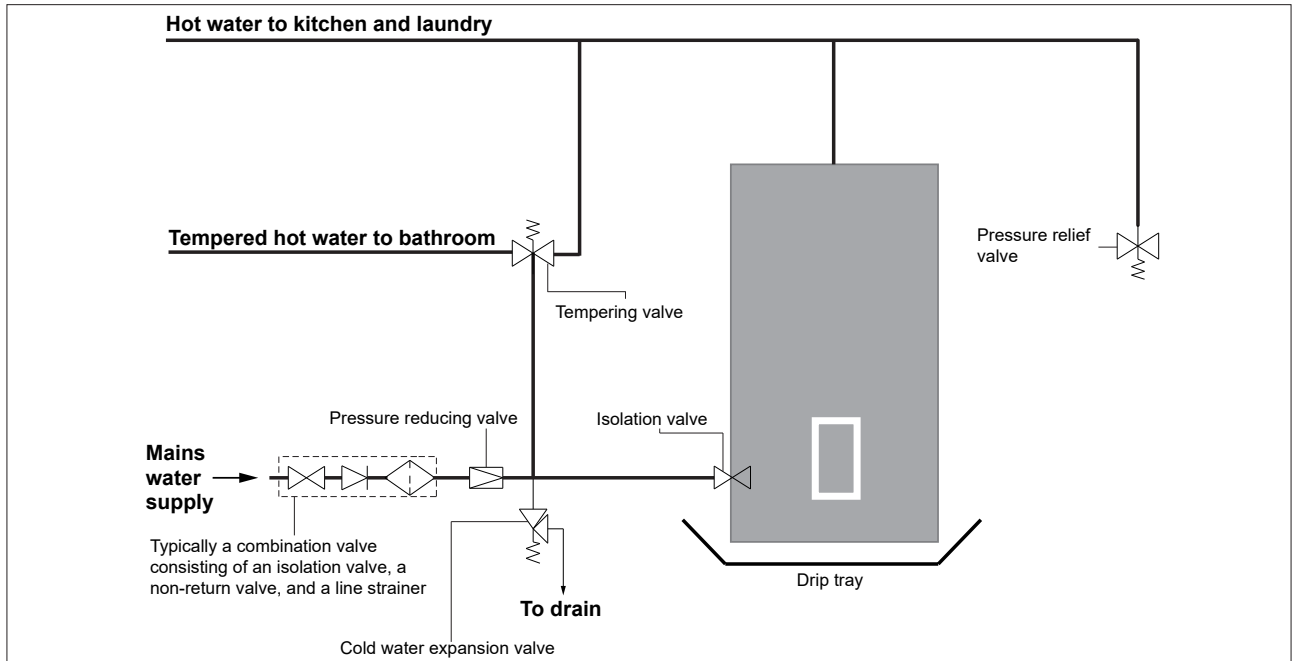

## Plumbing setup for a low pressure cylinder - open vented

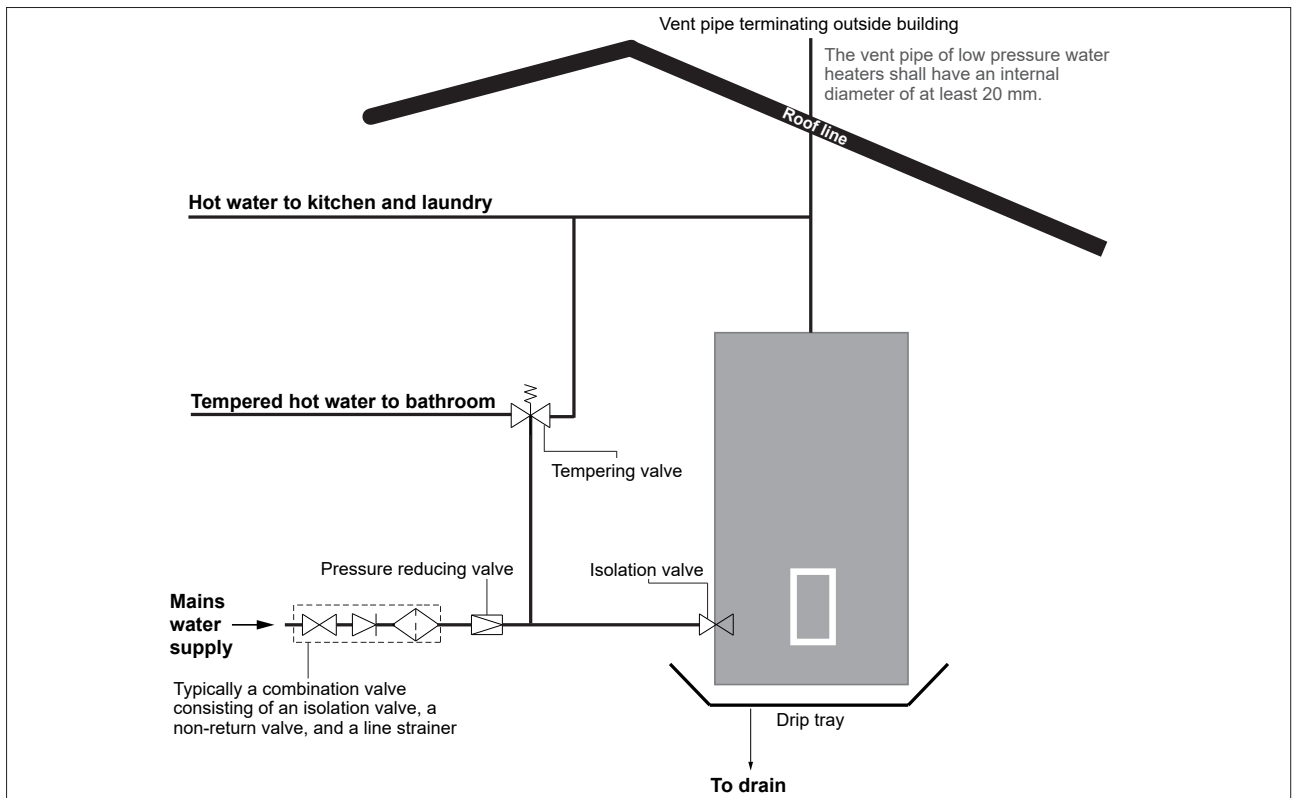

## Plumbing setup for a low pressure copper cylinder with a wetback

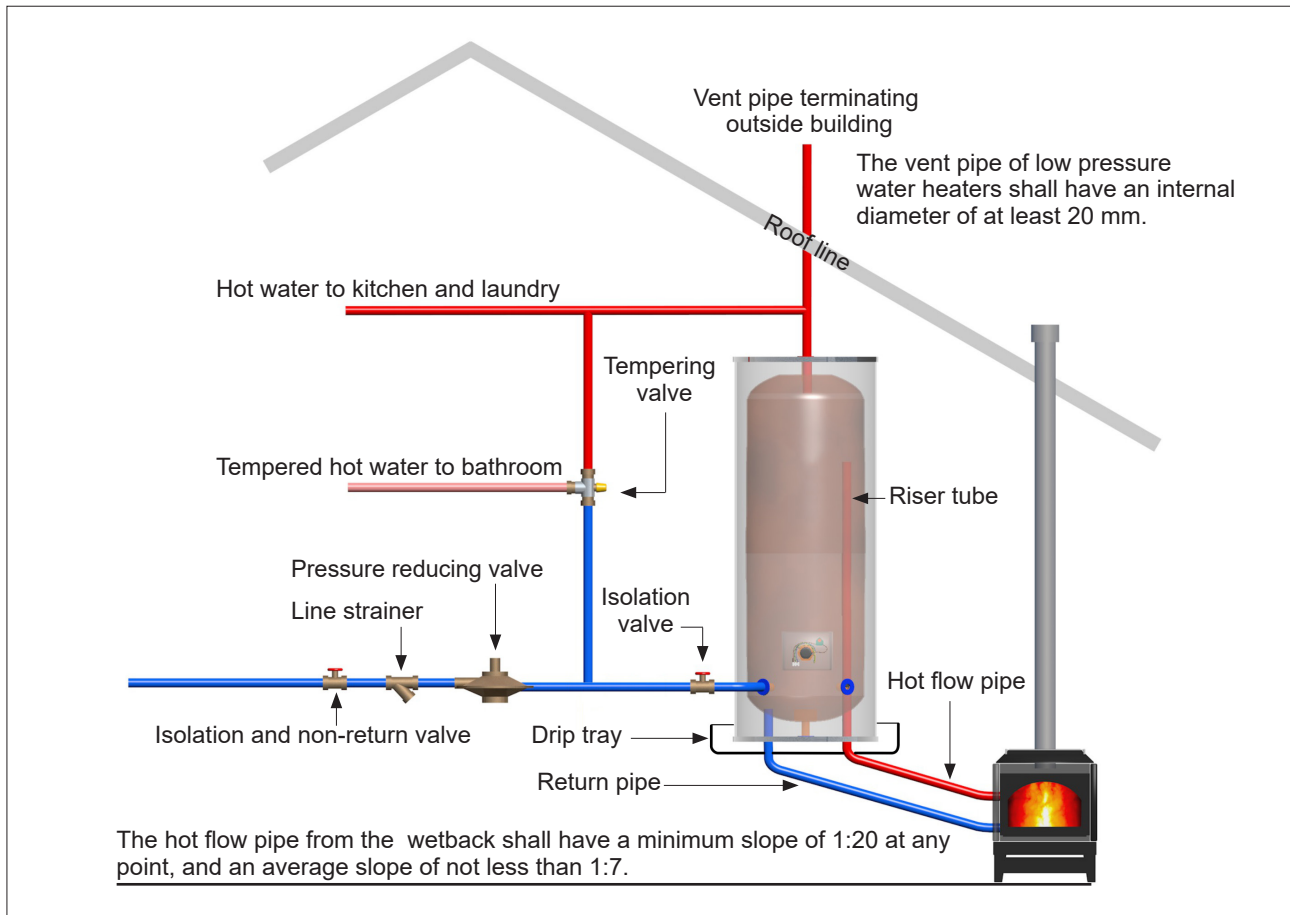

### Base requirements

Cylinders must be installed on a level and stable base capable of withstanding the weight of a full system. The structure must not shift.

### Seismic restraint

The water heater must be suitably restrained against seismic activity, 'G12/AS1 Figure 14' details an acceptable method of restraint.

### Safe tray

Where there is potential of damage occurring from a leaking system, a suitably drained safe tray must be fitted as per AS/NZS 3500.4 5.4 and G12/AS1 6.11.3.

### Pipe work

It is the installer's responsibility to adequately size the distribution pipe work in a property to ensure sufficient performance from all outlet fittings. Water pipe sizing should be performed in accordance with AS/NZS 3500.4 and/or G12/AS1. Pipe sizing and valve selection must be performed to allow for the water supply pressure.

DO NOT drill anything into the water heater, this could damage critical components and cause corrosion.

A drain off tap or line must be fitted to the inlet of the water heater.

# Storage and delivery temperatures

## Storage temperature

To meet the New Zealand Building Code requirement<sup>1</sup> to disinfect water for legionella bacteria, the cylinder thermostat has been preset to 65 °C (for standard cylinders), and approximately 70 °C (for wetback cylinders).



**WARNING**

- The access cover to the element and the thermostat must only be removed by an electrician or other suitable qualified tradesperson.
- Thermostat settings must only be adjusted by an electrician or other suitably qualified tradesperson.

## Hot water temperatures

NZBC G12.3.6 states that “*Where hot water is provided to sanitary fixtures and sanitary appliances, used for personal hygiene, it must be delivered at a temperature that avoids the likelihood of scalding.*”

In order to prevent scalding the delivered hot water temperature at any sanitary fixture used for personal hygiene must meet:

- G12/AS1 6.14.1 a)
- G12/AS1 6.14.1 b)

Sanitary fixtures used for personal hygiene includes showers, baths, hand basins and bidets.

In kitchens and laundries, heated water must be delivered to fixtures and appliances at flow rates and temperatures which are adequate for the correct functioning of those fixtures and appliances. The temperature required may be greater than 55°C.

To comply with these requirements, a temperature limiting device, such as a tempering or thermostatic mixing valve will be required on standard residential installations.

# Electrical supply and connections



The electrical connection must be carried out by a qualified person in accordance with the latest version of AS/NZS 3000 Wiring Rules. Disconnect all power prior to installation and commissioning.

The water heater must have the heating element connected to an independent, fused AC 230 V 50 Hz power supply with an isolating switch installed at the switch board. Ensure the isolating switch complies with AS/NZS 3000 4.8.2.3 *Isolating Switch*.

- The water heater must be filled with water prior to connection to the power supply.
- Household wiring to the system must be capable of withstanding the appliance load.
- Fixing wiring must be protected from contact with the internal surfaces of the system.

Electrical access for the tank is via a hole in the element cover for mounting with an approved electrical conduit gland (not supplied), this must be installed. For entry to the element cover remove the two fixing screws.

Connect all LIVE, NEUTRAL and EARTH wires in accordance with the wiring diagram. Inspect and ensure all wiring links are secure prior to fixing the access cover and turning the power on.

To ensure the over-temperature and energy cutout is set press the 'reset' button on the thermostat (not applicable for wetback cylinders)

The appliance is intended to be connected to cables of fixed wiring which has a cross-sectional area of 1.5 mm<sup>2</sup> - 2.5 mm<sup>2</sup>.

Once the cylinder is full of water perform an Earth Continuity Test, as outlined in Annex A of AS/NZS 60335.1.

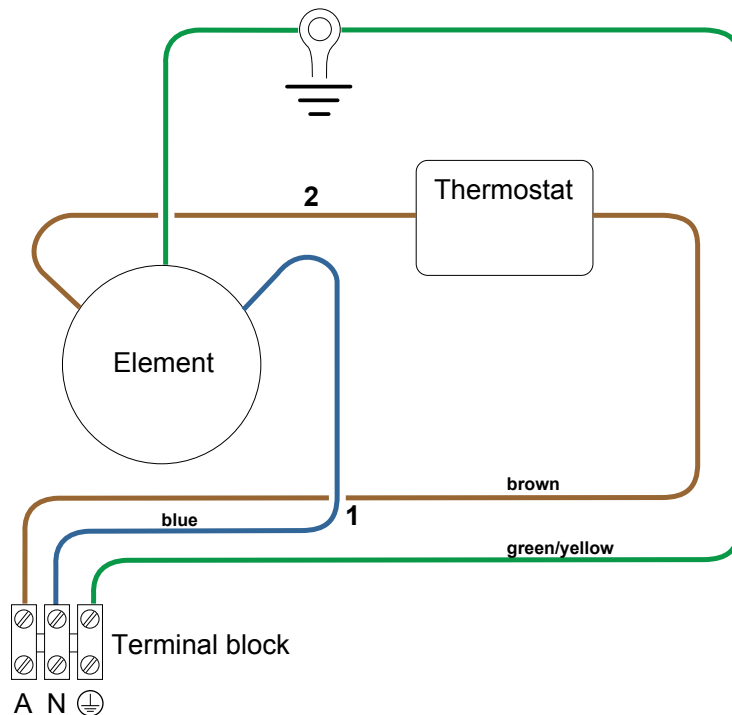

1	Wiring loom main low pressure	brown, green/yellow, blue	20080
2	Link wire brown low pressure	brown	20081

# Valves and fittings

Valves with pressure ratings other than those listed in this manual must not be used.

## Fittings supplied with the tank

Brass plugs, to plug unused connections, are packaged in a plastic bag inside the element cover, and a copper riser tube (for wetback tanks) is supplied.

# Commissioning

Commissioning and draining activities must be carried out by an authorised person.

## To fill and turn on the water heater

1. Open all hot water taps in the house including the shower.
2. Open the cold water isolation valve to the water heater. Air will now be forced out of the taps.
3. Close each tap when water runs freely without air bubbles.
4. Check all plumbing connections and pipe work for water leaks.
5. Switch on the electric power supply.

## To turn off the water heater

It may be necessary to turn off a water heater after installation and commissioning, for example during building activities or if the premises are vacant.

1. Switch off the electricity supply at the isolating switch to the water heater.
2. Close the cold water isolation valve at the inlet to the water heater.

## To drain the water heater

1. Turn off the heater, refer above.
2. Open all the hot water taps and then for valve vented (closed) installations, open the union at the top outlet to allow air into the tank and water to drain (ensuring no damage will occur from the discharged water).

# Undersink models - drain for service

Use the following procedure to drain undersink models:

1. Isolate the unit from the water mains.
2. Disconnect inlet port from cold water supply.
3. Open the hot water tap connected to the unit outlet.
4. Feed a 10-12 mm flexible hose into the inlet port of the unit. Feed the hose until it reaches the base of the cylinder.
5. Siphon the water out of the cylinder into a suitable drain or collection vessel.
6. Once the cylinder is drained remove siphon tube, disconnect hot water outlet connection, and remove cylinder.

# Limited Warranty



## Rinnai Low Pressure Copper Indoor Cylinder warranty summary

	<b>Residential application</b>	<b>Commercial application</b>
Cylinder only	5 years	1 year
Labour	1 year	1 year
All other parts <sup>1</sup> supplied by Rinnai	1 year	1 year
Labour	1 year	1 year

All terms of the warranty are effective from the first date of installation. Proof of purchase and installation date will be required at the time of any warranty claim. Where the date of installation is not known or cannot be proven, the warranty will commence one month after the date of manufacture—refer to the data label on the cylinder. This warranty is only valid within the country of purchase.

Any warranty claim must be made within a reasonable time of discovery of the potential fault or defect.

<sup>1</sup> All other parts include, but are not limited to; thermostats, elements, seals.

### General warranty terms

Rinnai reserves the right to make modifications and change specifications and its parts without notice.

For the purposes of the Consumer Guarantees Act 1993, Rinnai only guarantees the availability of repair facilities and spare parts for the express warranty periods recorded in the Rinnai warranty summary table.

If the Rinnai cylinder is being acquired for personal, domestic or household use<sup>2</sup>, this warranty does not limit any consumer rights or guarantees that may apply under the Consumer Guarantees Act 1993. If the product is being acquired for the purposes of a business<sup>3</sup>, the provisions of the Consumer Guarantees Act 1993 do not apply and no other warranties (either express or implied by law) apart from those stated in this warranty apply.

<sup>2</sup>A residential application is defined as an installation where the water heater, with the thermostat set at 70 °C and below, delivers hot water to a single family dwelling, not used for commercial purposes. Examples where a residential dwelling is used for commercial purposes: hair salon, catering kitchen, communal care facility etc. These installations would be considered commercial applications. An exception would be an accommodation business such as a motel, where the water heater serves the equivalent of a single family dwelling, this would be a residential application.

<sup>3</sup>A commercial application, constant use applications such as, but not limited to these, underfloor heating and circulating ring mains. The cylinder must be sized and installed according to written guidelines from Rinnai.



## Warranty terms and conditions

- All terms of this warranty are effective from the date of first installation. The attending service person reserves the right to verify this date.
- All Rinnai appliances must be installed, commissioned, serviced, repaired and removed in accordance with the manufacturer's instructions, local regulations, and municipal building codes by persons authorised by local regulations to do so.
- All appliances must be operated and maintained in accordance with the manufacturer's operating instructions.
- This warranty applies only to the components supplied by Rinnai. It does not apply to components supplied by others, such as, isolating valves, electrical switches, pipe work, electrical cables, fuses, but not limited to these.
- Where the appliance has not been sited in accordance with the installation instructions or installed such that normal service access is difficult, a service charge will apply. If at the discretion of the attending service person the installation is deemed illegal or access is dangerous, service will be refused. Any work required to gain access to the appliance will be chargeable by the attending service person (for example, removal of walls, or the use of special equipment to move components, but not limited to these).
- Where a failed component is replaced under warranty, the balance of the original appliance warranty will remain effective. The replacement part or appliance does not carry a new warranty.
- Rinnai reserve the right to transfer functional components from defective appliances if they are suitable.
- Rinnai reserve the right to have installed product returned to the factory for inspection.
  - The decision of whether to repair or replace a faulty component of the cylinder is at the sole discretion of Rinnai.
  - Where Rinnai determines that the cylinder needs to be removed for repair, Rinnai may undertake such removal and may permanently replace the defective unit with a substitute unit that is the reasonable opinion of Rinnai, in a better or equal condition to the unit being replaced.
- Where the heat pump is installed outside the metropolitan area or further than 40 km from an authorised repairer, travel costs shall be the owner's responsibility.

## Warranty exclusions

The following exclusions may cause the warranty to become void and will result in a service charge and costs of parts (if required).

- Accidental damage, defects or failure caused by acts of nature (fire, wind, lightning, flood, storm, hail storm fallout), vandalism, earthquake, war, civil unrest, pests, animals, insects, or entry of foreign objects or matter into the product such as dirt, debris or moisture.
- Defects or failure due to environmental damage such as corrosion.
- Failure due to abuse or misuse, improper maintenance or improper storage.
- Failure due to incorrect or unauthorised installations.
- Failure or damage caused by alterations, service or repair work conducted by individuals not authorised by Rinnai.
- Where the cylinder has failed directly or indirectly as a result of poor water quality outside the limits specified (refer next page).

- Where it is found that there is no fault with the appliance and the issue is related to the installation or is due to power failure.
- Subject to any statutory provisions to the contrary, Rinnai does not accept:
  - Liability for consequential damage or any incidental expenses resulting from any breach of the warranty.
  - Claims for damage to buildings or any other consequential loss either directly or indirectly due to leaks from the cylinder or any other faults.

## Water quality

Water chemistry has a direct impact on hot water heaters, affecting corrosion protection measures, or causing scale buildup.

Water quality MUST:

1. Meet the Water Services (Drinking Water Standards for New Zealand) Regulations 2022 and the Aesthetic Values for Drinking Water Notice 2022, or the water standards as statutorily defined at the time; AND
2. Be within the limits shown in the table below.

Water quality outside these limits will void this warranty.

### Water quality and impurity limits

<b>TDS (Total Dissolved Solids)</b>	<600 mg/L	<b>Manganese</b>	<0.01 mg/L
<b>Total Hardness CaCO<sub>3</sub></b>	<200 mg/L	<b>Sodium</b>	<150 mg/L
<b>Alkalinity</b>	150-200 mg/L	<b>Iron</b>	<0.1 mg/L
<b>Dissolved (free) CO<sub>2</sub></b>	<25 mg/L	<b>Sulphate</b>	<100 mg/L
<b>pH</b>	6.8-7.5	<b>Nitrate</b>	<11 mg/L
<b>Chlorides</b>	<150 mg/L	<b>Alkalinity/Sulphate ratio</b>	>1
<b>Free Chlorine</b>	<1 mg/L	<b>LSI<sup>1</sup></b>	-1.0-0.8 @20 °C
<sup>1</sup> Langelier Saturation index			

## Water quality warranty guidelines

### Filtration

Where there is discolouration, foreign debris, or silt present in the water, an inline filter must be fitted into the water supply to protect the copper water heater from corrosion. Particulates and deposits in hot water systems are corrosive to copper and stainless and can lead to premature pitting. The filters must be periodically replaced to maintain the integrity of the system.

### Stagnation

Leaving water stagnant in the system will promote corrosion. It is recommended that systems, if not in use, are flushed on an eight week cycle.

### Bore and tank water

Bore and tank water supplies should be considered to be corrosive and should be tested prior to using the system. Bore and tank water must meet the water quality parameters stated in the above table.

# Warranty examples in the real-world

We understand warranty information can be confusing. To help clarify what this means in the real-world we have developed some residential application scenarios to clarify what would fall within warranty and what wouldn't.

Scenario	Age of part/ cylinder	Within warranty	
Faulty thermostat	10 months	Yes	All costs covered by Rinnai.
Faulty element	3 years	No	All costs covered by the owner.
Cylinder leaks and causes damage to carpets and flooring	11 months	Yes/No	Cost of cylinder replacement covered by Rinnai. Consequential loss, damage to carpets and flooring, is not <sup>1</sup> .
Cylinder fails	4 years	Yes	Cost of cylinder replacement covered by Rinnai. The cost of removal of the cylinder, re-installation, and labour costs are the responsibility of the owner.

## <sup>1</sup> Consequential losses

All cylinders, that have the potential to leak water, are required to be installed with a drip tray. If damage is caused by a leaking cylinder that has not been installed with a drip tray the owner can seek compensation through the installer or consider claiming on insurance.

# Purchase details

Record your purchase details below

	ATTACH YOUR PROOF OF PURCHASE HERE: 
Retailer: _____	
Retailer address: _____ _____	
Date of purchase: _____	
Product details: _____ _____ _____	
<b>Please keep these details in a safe place for future reference.</b>	

**Register your Rinnai cylinder online** at [www.rinnai.co.nz/register/](http://www.rinnai.co.nz/register/) for service reminders, product updates and special offers—you can unsubscribe at any time.

# Installer details

Company name: _____	
Installer name: _____	
Address: _____ _____	
Phone: _____	Mobile: _____
Signed: _____	Date: _____

**Rinnai.co.nz**

Tel: 0800 746 624  
<http://www.youtube.com/rinnainz>  
<http://facebook.com/rinnainz>

20733-K